

**INSTALLATION INSTRUCTIONS**  
for DOUBLE PLUNGER PUSHBUTTON SWITCHES

00579-101	00579-132	00580-001	00580-032	01531-032	01619-014
01619-032	01896-032	01957-032	01968-032	01968-132	01968-232
02140-032	02169-032	02276-032	02712-032	02810-001	02810-032
02810-132	02883-032	03605-032	03605-132	03605-232	03924-000
04062-032	04062-132	04062-432	04087-032	04596-001	04932-032
04932-132	04932-232	04932-432	04932-532	04932-632	04947-032
					04947-132

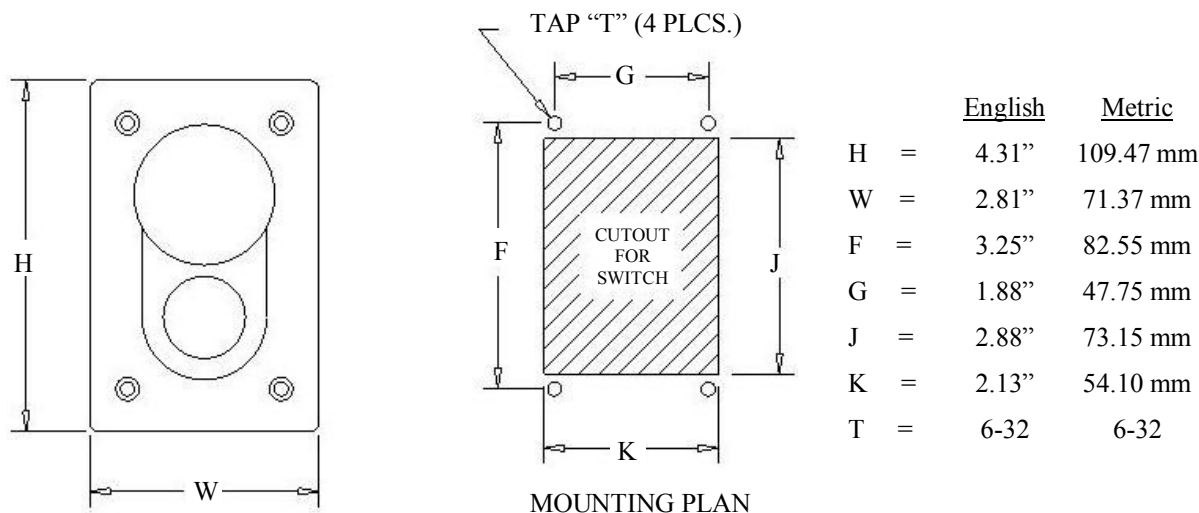

Note: See current Specifiers Guide for detailed dimensional drawings of each device.

**INSTALLATION:**

1. Observe all SAFETY REQUIREMENTS and PROCEDURES during installation, set-up and running.
2. N.E.C. and local wiring codes MUST be followed at all times.
3. The cable switch MUST be mounted on or in an enclosure (Mounting screws are supplied with each switch).
4. Before wiring be sure to place the supplied gasket on the switch.
5. Wire as required, torque each used terminal screw to 18 in.-lbs. (20.7 cm-kg).
6. After wiring, place the switch into the enclosure taking care to route the wires away from the back of the switch so that they do not become entangled and interfere with the operation of the device.
7. Secure the switch with the mounting screws. Torque to approximately 7 in./lbs. (8.06 cm-kg).
8. Wiring SHOULD be through a control circuit.
9. After applying power to the control circuit, operate the device to check for proper installation.

**MAINTENANCE:**

1. Regular Preventive Maintenance inspections are recommended.
2. Some conditions to watch for are:
  - a. Physical damage to the device.
  - b. Frayed wiring.
  - c. Any loose components.
  - d. Any worn components.
3. If other assistance is desired please contact the factory.

**SPECIFICATIONS / APPROVALS**  
for DOUBLE PLUNGER PUSHBUTTON SWITCHES

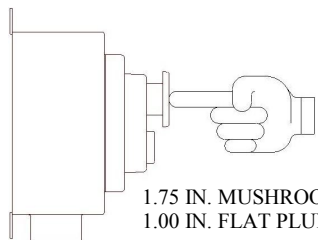

1.75 IN. MUSHROOM PLUNGER  
1.00 IN. FLAT PLUNGER

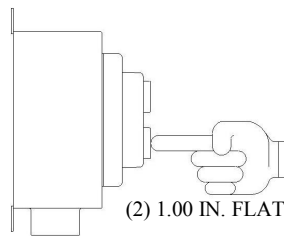

(2) 1.00 IN. FLAT PLUNGER

Catalog Number	Contact Arrangement	1st Plunger			2nd Plunger		
		Size/Style	Color	Operation Type	Size/Style	Color	Operation Type
00579-101	#17 (NO + NO/NC)	1.00" F	Black	Momentary	1.00" F	Black	Momentary
00579-132	#17 (NO + NO/NC)	1.00" F	Green	Momentary	1.00" F	Red	Momentary
00580-001	#04 (NO + NC)	1.00" F	Black	Maintained	1.00" F	Black	Maintained
00580-032	#04 (NO + NC)	1.00" F	Green	Maintained	1.00" F	Red	Maintained
01531-032	#23 (NO + NO/NC)	1.00" F	Green	Maintained	1.00" F	Chrome	Zinc
01619-014	#02 (NO + NC)	1.00" F	Black	Momentary	1.75" M	Yellow	Momentary
01619-032	#02 (NO + NC)	1.00" F	Green	Momentary	1.75" M	Red	Momentary
01896-032	#04 (NO + NC)	1.00" F	Red	Maintained	1.75" M	Green	Maintained
01957-032	#68 (NO/NC+NO/NC)	1.38" M	Green	Maintained	1.38" M	Red	Maintained
01968-032	#68 (NO/NC+NO/NC)	1.00" F	Green	Maintained	1.75" M	Red	Maintained
01968-132	#60 (NO + NC) MBB	1.00" F	Green	Maintained	1.75" M	Red	Maintained
01968-232	#68 (NO/NC+NO/NC)	1.00" F	Green	Maintained	1.75" M	Red	Maintained
02140-032	#02 (NO + NC)	1.00" F	Green	Momentary	1.00" F	Red	Momentary
02169-032	#04 (NO + NC)	1.38" F	Green	Maintained	1.38" F	Red	Maintained
02276-032	#02 (NO + NC)	1.38" F	Green	Momentary	1.38" F	Red	Momentary
02712-032	#60 (NO + NC) MBB	1.38" M	Green	Maintained	1.38" M	Red	Maintained
02810-001	#67 (NO/NC+NO/NC)	1.38" F	Black	Momentary	1.38" F	Black	Momentary
02810-032	#67 (NO/NC+NO/NC)	1.38" F	Green	Momentary	1.38" F	Red	Momentary
02810-132	#68 (NO/NC+NO/NC)	1.38" F	Green	Maintained	1.38" F	Red	Maintained
02883-032	#60 (NO + NC) MBB	1.00" F	Green	Maintained	1.00" F	Red	Maintained
03605-032	#29 (NO + NO/NC)	1.00" F	Green	Momentary	1.75" M	Red	Maintained
03605-132	#29 (NO+NO/NC) MBB	1.00" F	Green	Momentary	1.75" M	Red	Maintained
* 03605-232	#69 (NO/NC+NO/NC) MBB	1.00" F	Green	Maintained	1.75" M	Red	Maintained
03924-000	#06 (NO + NO)	1.00" F	Aluminum	Momentary	1.00" E	Aluminum	Momentary
04062-032	#15 (NO/NC + NC)	1.00" F	Green	Momentary	1.00" F	Red	Momentary
* 04062-132	#17 (NO + NO/NC)	1.00" F	Green	Momentary	1.00" F	Red	Momentary
04062-432	#68 (NO/NC+NO/NC)	1.00" F	Green	Maintained	1.00" F	Red	Maintained
04087-032	#02 (NO + NC)	1.00" F	Green	Momentary	1.75" M	Red	Momentary
04596-001	#07 (NC + NC)	N/A	--	Maintained	1.75" M	Black	Maintained
04932-032	#29 (NO + NO/NC)	1.00" F	Green	Momentary	1.75" M	Red	Maintained
04932-132	#29 (NO+NO/NC) MBB	1.00" F	Green	Momentary	1.75" M	Red	Maintained
* 04932-232	#69 (NO/NC+NO/NC) MBB	1.00" F	Green	Maintained	1.75" M	Red	Maintained
04932-432	#68 (NO/NC+NO/NC)	1.00" F	Green	Maintained	1.75" M	Red	Maintained
04932-532	#29 (NO + NO/NC)	1.00" F	Green	Momentary	1.75" M	Red	Maintained
04932-632	#29 (NO+NO/NC) MBB	1.00" F	Green	Momentary	1.75" M	Red	Maintained
04947-032	#64 (2NO + 2NC)	1.00" F	Green	Maintained	1.00" F	Red	Maintained
04947-132	#64 (2NO + 2NC)	1.00" F	Green	Maintained	1.75" M	Red	Maintained

These switches comply with:

**UL listed**  
UL-508;  
File E 58589

**CSA certified**  
CSA—C 22.2  
No. 14;  
File LR 3648

**Demko (3rd Party)**  
and

**CE Marked**  
per  
EN 60947-5-1:2004  
+ A1:2009;

**IEC Ratings:**

Utilization:  
A 600, AC 15;  
N 300, DC 13;  
U<sub>e</sub> = 600 vAC;  
U<sub>e</sub> = 250 vDC,  
U<sub>i</sub> = 600 vAC,  
U<sub>imp</sub> = 2.5 kV;  
I<sub>th</sub> = 10A

Temperature:

Operating:  
0°C to +55°C  
(-32°F to +131°F);

Storage:  
-40°C to +85°C  
(-40°F to +185°F)

**Mechanical Life:**

500,000 operations

**WARNING - DANGER**

These products should only be used where point-of-operation guarding devices have been properly installed and maintained so that all appropriate OSHA and ANSI B11.1 regulations and standards are met. Misapplication of these products on machinery lacking effective point-of-operation safeguards can cause serious injury to the operator of that machinery.

**AVERTISSEMENT - DANGER**

Ces produit doivent seulement être utilisés sur des postes à risque correctement sécurisés et entretenus afin d'être conforme aux standards et régulations en vigueur (CSA, CLC). Un mauvais usage de ces produits sur des machines et des postes de travail non sécurisés de manière efficace peut causer des blessures graves au technicien maniant ces machines.